

Building Sketch (Page - 1)

Borrower				
Property Address 505 Hogan Farm Rd				
City	Chapel Hill	County	Orange	State NC Zip Code
Lender/Client				

Large Irregularly Shaped Paver Patio

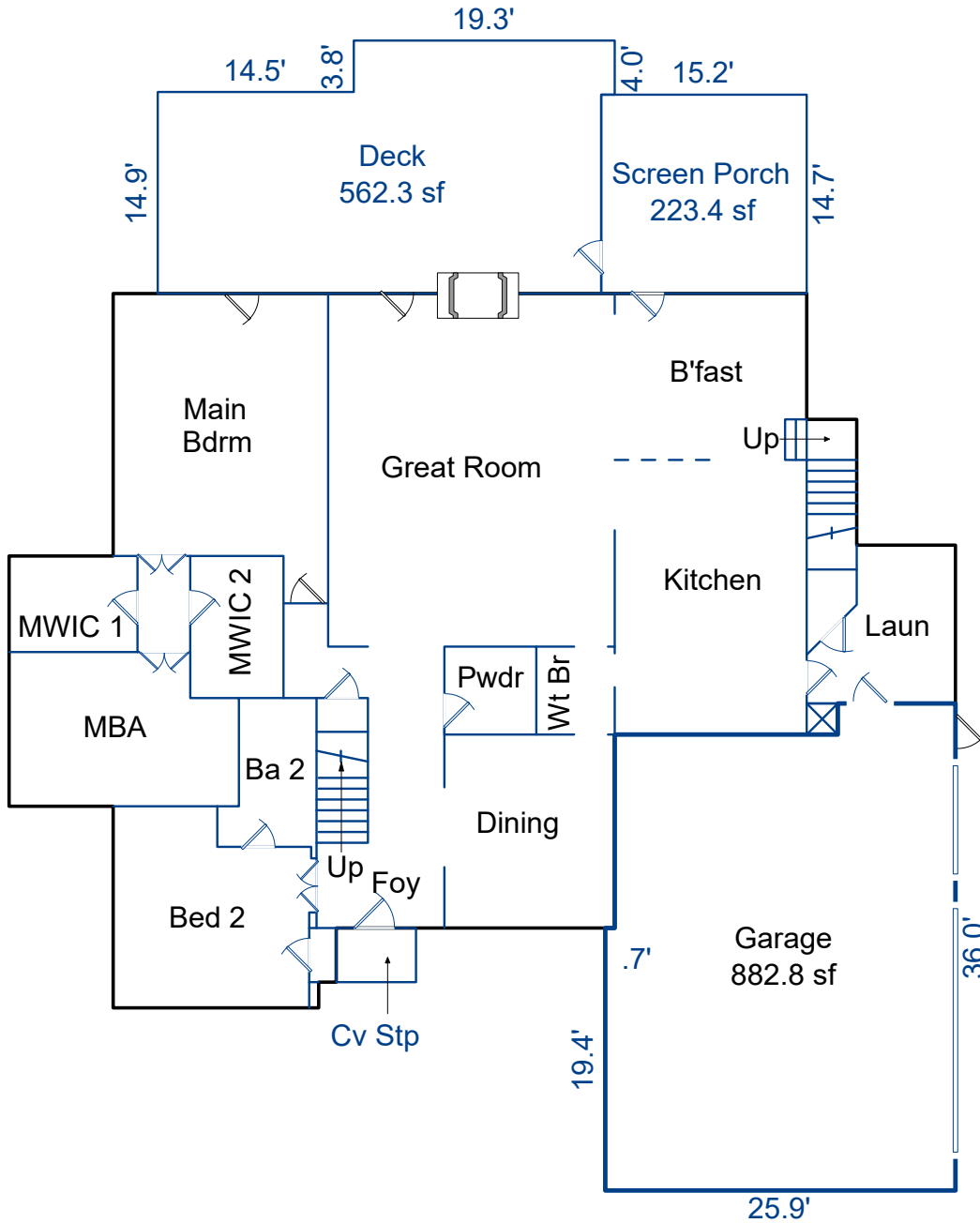

Sketch by Apex Sketch

AREA CALCULATIONS SUMMARY						AREA CALCULATIONS BREAKDOWN				
Code	Description	Factor	Net Size	Perimeter	Net Totals	Name	Base x	Height x	Width =	Area
GAR	Garage	1.0	882.8	123.8	882.8					
P/P	Cv Stp	1.0	23.6	19.8						
	Deck	1.0	562.3	105.0						
	Screen Porch	1.0	223.4	59.8	809.3					
UND	First Floor	1.0	2608.6	245.6	2608.6					
						0 total items (rounded) 0				

Building Sketch (Page - 2)

Borrower				
Property Address	505 Hogan Farm Rd			
City	Chapel Hill	County	Orange	State NC Zip Code
Lender/Client				

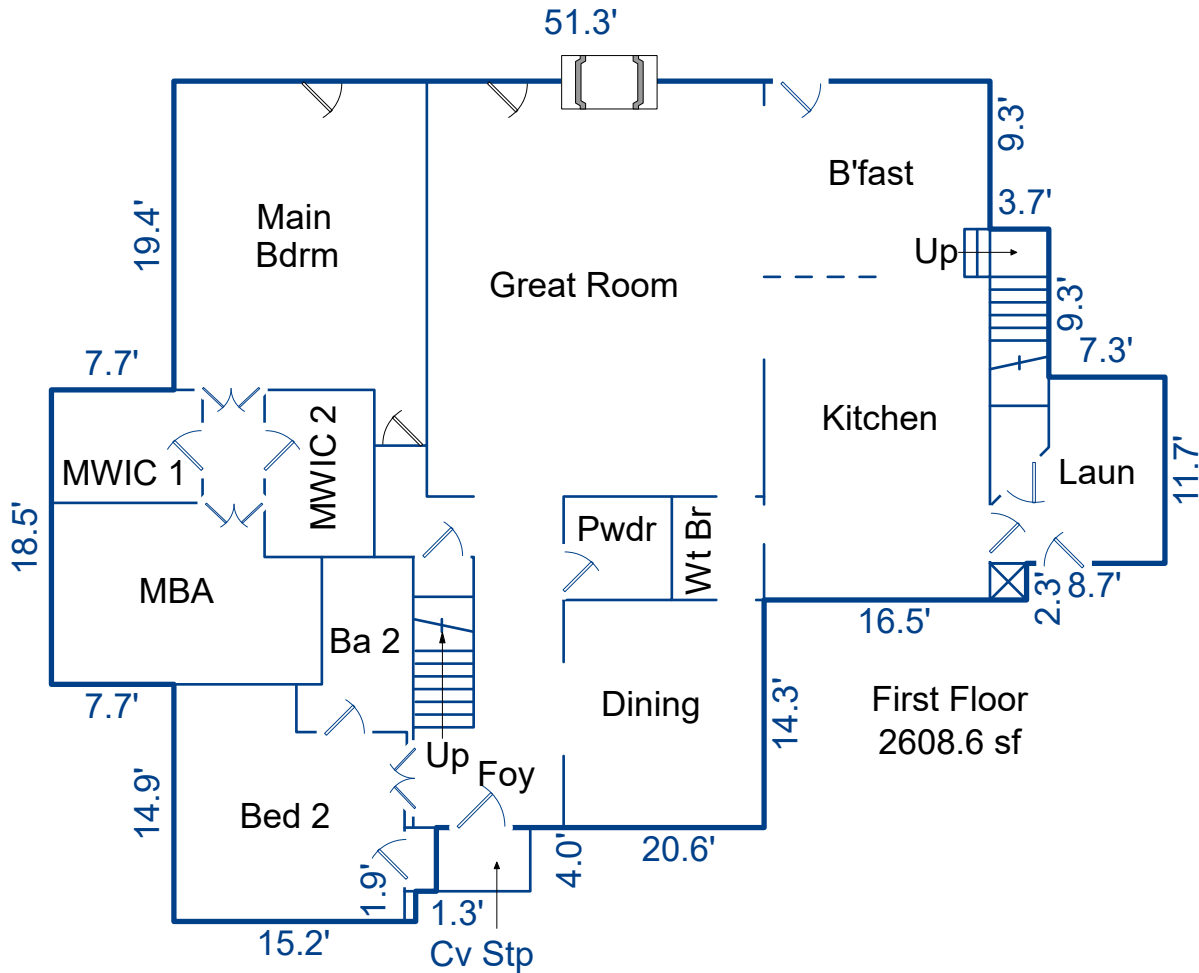

Sketch by Apex Sketch

AREA CALCULATIONS SUMMARY						AREA CALCULATIONS BREAKDOWN				
Code	Description	Factor	Net Size	Perimeter	Net Totals	Name	Base x	Height x	Width =	Area
GLA1	First Floor	1.0	2608.6	245.6	2608.6	First Floor	18.5 x	7.7 =	142.5	
P/P	Cv Stp	1.0	23.6	19.8	23.6		53.6 x	14.0 =	750.4	
							37.1 x	14.3 =	530.5	
							11.7 x	8.7 =	101.8	
							16.5 x	4.0 =	66.0	
							55.0 x	9.3 =	511.5	
							15.2 x	1.9 =	28.9	
							51.3 x	9.3 =	477.1	
	Net LIVABLE		(rounded)		2,609	8 total items		(rounded)		2,609

Building Sketch (Page - 3)

Borrower				
Property Address	505 Hogan Farm Rd			
City	Chapel Hill	County	Orange	State NC Zip Code
Lender/Client				

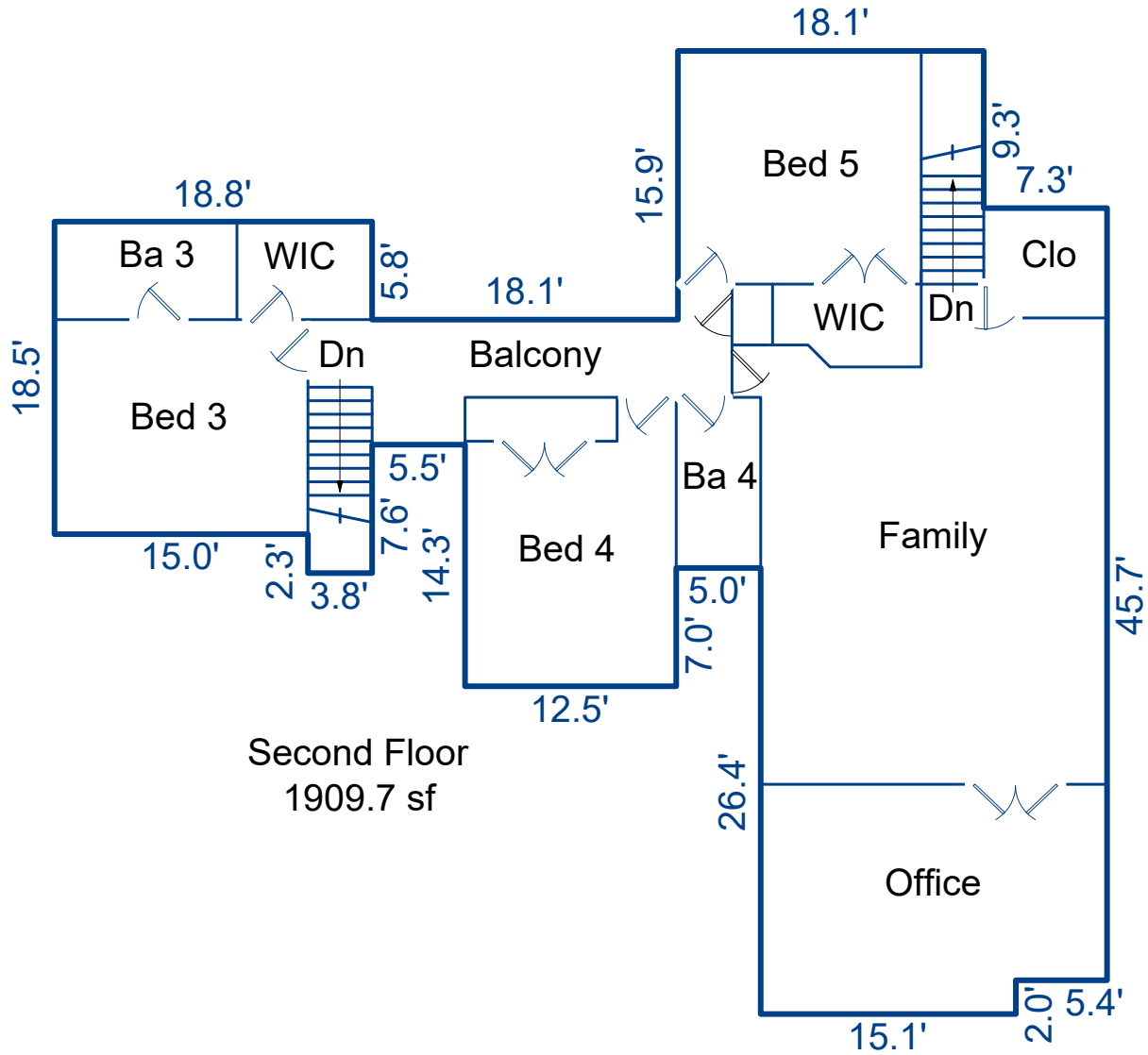

Sketch by Apex Sketch

AREA CALCULATIONS SUMMARY					AREA CALCULATIONS BREAKDOWN					
Code	Description	Factor	Net Size	Perimeter	Net Totals	Name	Base x	Height x	Width =	Area
GLA2	Second Floor	1.0	1909.7	279.4	1909.7	Second Floor		45.7 x	20.5 =	936.9
								15.1 x	2.0 =	30.2
								13.2 x	9.3 =	122.8
								30.6 x	4.9 =	149.9
								21.7 x	12.5 =	271.3
								7.4 x	5.5 =	40.7
								14.7 x	0.1 =	1.5
								20.8 x	3.8 =	79.0
								18.5 x	15.0 =	277.5
	Net LIVABLE		(rounded)		1,910	9 total items			(rounded)	1,910